

Operation Manual

Single Pole Electric Elevator

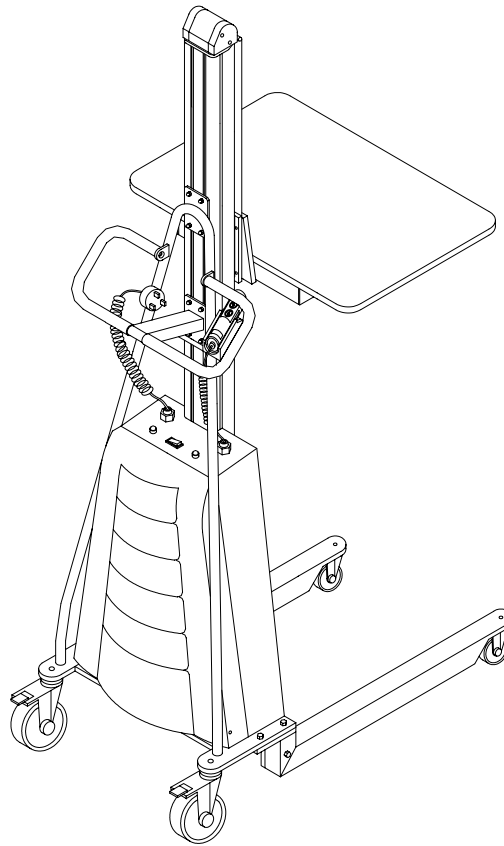

NOTE: The Owner/Operator must read carefully and understand all the information presented here before operation.

CONTENT

1. Dimension & Parameter Chart
2. Part Name
3. Warning
4. Check Before Assembly
5. Operation Guide
6. Daily Maintenance & Periodic Inspection
7. Trouble Shooting
8. Explosive Graphics
9. Chart of Parts

Thank you for your using this series of Elevators

This manual describes right operation method for ensuring safety and the right ways of maintenance, which prolongs the working life of the equipment. The operator must read carefully and understand all the information presented here.

This series of Electric Elevators are easy to handle with, safe and reliable, automatic and labor saving by small but high efficient and maintenance free cell power supplying, reliable small motorized chain driving , high performance panel control; movable electric push buttons control the movements of platform or other accessory upward or downward.

This series of Electric Elevators are mainly used for goods transition, elevation or piling, or taking off and transiting goods at some certain height on plain and smooth floor. The characteristics of pretty appearance, high intensity aluminum alloy pole, convenient and movable electric control, automatic and labor saving make the elevators be extensively used in. Especially, the configuration of several accessories and provision grade platform make the elevators be specially applied in transition of small column shaped working pieces, such as in packing material printing factories, super-markets, hotels and etc.

1. Dimensions & Parameter Chart

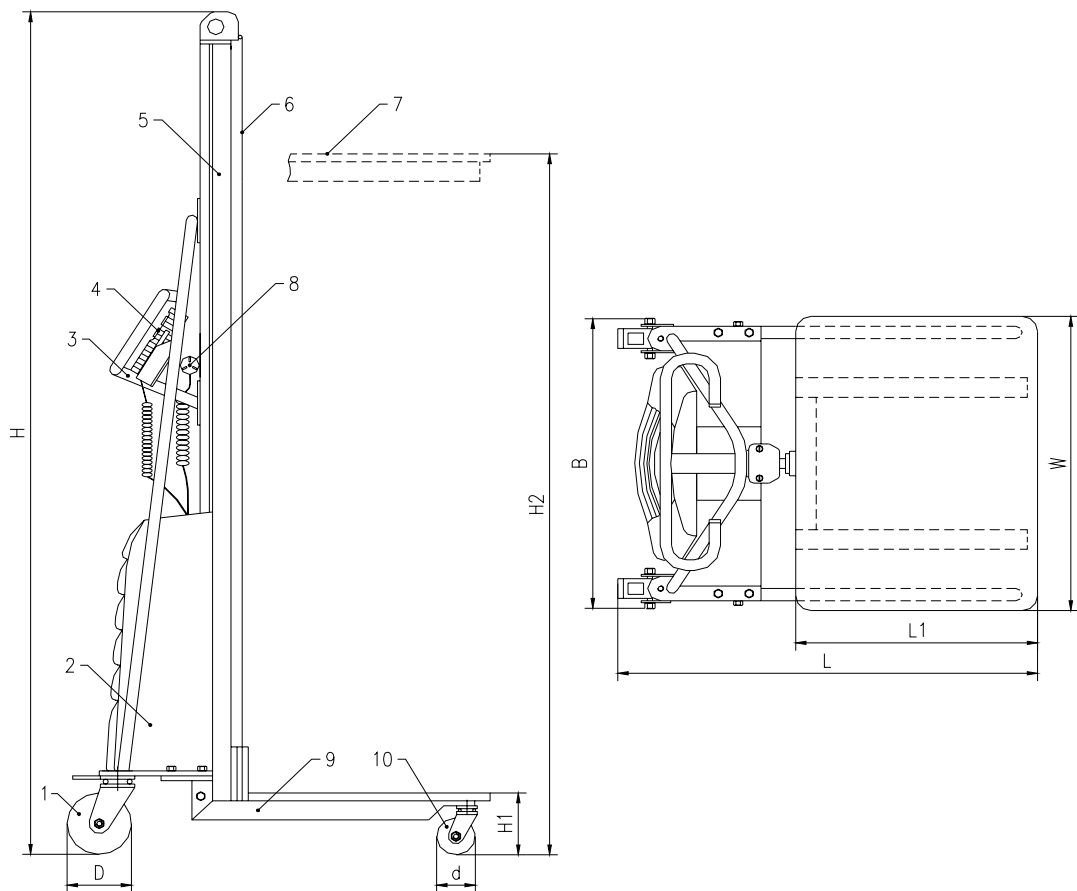

Model		
--------------	--	--

Load Capacity	(Kg)	100	150
Load Center C	(mm)	235	235
Height min. H1	(mm)	130	130
Height max. H2	(mm)	1700	1500
Platform Size L1×W	(mm)	470×600	470×600
Dimension L×W×H	(mm)	890×600×1980	890×600×1780
Front Wheel d	(mm)	Φ75	Φ75
Rear Wheel D	(mm)	Φ125	Φ125
Maintenance Free Cell	24V/12Ah		
Weight	(Kg)	58	55

2. Part Name

- | | |
|-----------------------------------|---|
| 1. Rear Wheel | 2. Electric Control of Transmission Box |
| 3. Handrails | 4. Movable Handy Panel |
| 5. Aluminum Alloy Pole | 6. Safety Belt |
| 7. Platform (Various Accessories) | 8. Socket for Charger |
| 9. Chassis | 10. Front Wheel |

3. Warning

1. Use only on plain and smooth floor.
2. Don't overload, ensure load uniformity. Pay special attention when heavily loaded.
3. Buzzer beeps to alarm cell low, charge in time or the cell shall be damaged.
4. Ensure that the input voltage of the charger complies with local power net voltage.
5. Not to contact chain or other moving parts.
6. Not to carry out long hours of continuous work under heavy duty, lest troubles from over heated of motor and panel.
7. The working life of the elevator shall be greatly prolonged when working under 0.7 times of the maximum nominal load.
8. Keep the electric control commission box closed before operation.

4. Check before Assembly

E Series of single pole electric elevator is delivered in box with dis-assembled parts, and before exit factory, the product is adjusted. Please follow the following regulations to assemble and inspect the product before putting into use.

1. Ensure the parts received are complete, in good condition and appearance free from any damage.
2. Connect fast two pieces of front wheel forks (45) by bolts (43 and (46) to the supports of

electric box (3) separately.

3. Connect fast the fixed fork (27) by bolt (28) to safety belt (23), downward/upward bearing seat (35) separately, without loosening and ensure the safety belt is totally clamped firmly.
4. Switch (5) power ON without load, (Buzzer may beep, switch off/on again, beep stops); operate the hand panel (16), platform (26) climbs smoothly up to the height maximum, keeps still, and then descends to the lowest position. The total commission makes no abnormal sound.
5. Repeat the afore mentioned operation under rated load, the platform shall climb smoothly to the height maximum, stop without slipping, or descend smoothly to the lowest position and stop then without abnormal sound.
6. The maintenance-free cell, which is provided together with the elevator, has been initially charged full before exit plant. Provided the interval from exit plant is relatively long, the cell may be no more full. Hence, for the first time heavy load climbing when buzzer beeps, it is necessary to charge again before reuse.

5. Operation Guide

1) Elevator: Operation of Transition, Loading and Unloading.

Lock truckles before goods loading and unloading at any height.

Take care of load uniformity when load and unload; deflected load is always not appreciated.

Mention not to loose equilibrium from one-sided unloading lest dangerous occurrences.

When it is needed to move the elevator with unfinished unloading, take care of the uniformity of the goods still needed to be unloaded.

Lower the platform to the lowest position when the loaded elevator is to move, so as to ensure safety.

2) Elevator: Operation of Climbing and Descending

- 2.1 Take care to stop at a right spot and ensure needed operation space when the elevator is to pile or take off goods for some height.
- 2.2 Lock the wheels, and switch power on.
- 2.3 Press on the UP button on the panel, the platform climbs smoothly to the needed height, and then release the button, the platform keeps still and shall not slip down. The movable hand control panel is convenient for the operator to observe and operate on different positions.
- 2.4 Strictly follow the regulations (1.1, 1.3, 1.4) to operate the elevator when goods raised up to the needed height for unloading or piling.
- 2.5 Strictly follow the regulations (1.1, 1.2, 1.5) to operate the elevator when taking off goods from ratchet.
- 2.6 When finishing unloading at some height, press the SOWN button for the platform

descending smoothly; and the DOWN button can be released at any height needed while the platform shall stop descending for the elevator to perform a new job at same spot but different height.

- 2.7 The elevator is designed to possess the function of overload protection. Whenever the load surpassed 25% of rated capacity, the platform shall not be elevated, the elevator shall not be able to carry out the jobs of up-climbing, down-descending and vehicle transition.
- 2.8 The elevator is designed to possess the function of low power protection. Should the cell power is not sufficient for jobs during loaded climbing and descending, the buzzer beeps for 50 seconds alarm continuously and then cut off automatically the power circuit with indication light up (operator shall lower the platform to the lowest position during this period); the elevator is protected and the operation of climbing or descending is invalid even if the power is still connected.

3) Cell

- 3.1 High performance petty maintenance-free sealed acidic-lead storage cell is selected to power the elevator. It is characterized by low discharge ability, safe, easy mounting and change-over, and can be used under the ambient temperature range of $-15^{\circ}\text{C}\sim 50^{\circ}\text{C}$.
- 3.2 The working life of the cell is greatly depends on the right use. The working life of the cell shall be greatly shortened when repeatedly used at the condition of low voltage, and even burn the control element. Considering of this, the elevator is designed with the function of low voltage protection in the part of electric control. During the elevator is operating under low voltage for up-climbing or down-descending, the buzzer shall beep for 50 seconds continuously and then cut off the power supply. The operator shall charge the cell in time.

4) Charger

- 4.1 High performance charger is provided together with the elevator, so that the cell can be charges at any handy power terminal. Be sure the voltage of local power net is as needed by the inlet voltage of the charger.
- 4.2 When charging with switch off elevator power, connect charger source pin and power terminal socket, the red indicator of source power of the charger is lit up, while the charging status green indicator is lit, that means the cell is tin the status of charging; and when the green indicator faded, that means the cell is charged full. Generally, the charging period takes 10~12 hours.
- 4.3 Shall the charged cell show low voltage status during heavy duty job, probably the cell is damaged or the charger is in trouble.

5) Safety Belt

- 5.1 Safety belt is a safety device provided for preventing the transmission chain to break suddenly and that may cause equipment damaging. The device makes the elevator possess the characteristics of safe and reliable.

6. Daily Maintenance & Periodic Inspection

1. Check if right every day for each status indication, including the smoothness and stability of platform up-climbing and down-descending.
2. Check once a month if any deformation, connection loosening, wearing and abnormal sound for connecting bolts, wheels, rolling bearing, transmission chain, structure parts and moving parts.
3. Check once a month the jiggling, wearing, lubricating, and loosening for chain, sprocket wheel, chain-trolley and connecting bolts inner transmission box, grease in time, as well.
4. Once each three months check control panel, charger, cell and electric control wiring if any loosening inner transmission box and the inner box cleaning.
5. Check each month the bending and deforming status of the pole, and if the flexible and smooth for the safety belt protruding and retrieving.

7. Trouble Shooting

No.	Description	Cause	Treatment
1	Power on, press UP button, platform not climbing up.	1.Power switch damage	Check and changeover
		2.Wire off	Check and connect
		3.Cell dead or damaged	Charge of change
		4.Button fail or wire off	Check and changeover
		5.Panel fuse burnt	Changeover
		6.Motor damaged	Check or changeover
		7.Overload	Partial unloading
		8.Lowest Position traveling switch fail	Check or changeover
2	Press UP button, climbing slowly or not climbing up	1.Cell low or over discharged	Charge in time
		2.Motor trouble, RPM lowered	Check or changeover
		3.Panel adjustment fail	Re-adjust panel
3	Platform can not climb to the height max.	1.Barrier inner guiding rail	Clear away barrier and lubricating
4	Platform climbed to the height max but fail to descending	1.DOWN button fail	Check or changeover
		2.Travelling switch inner panel fail	Check or changeover
		3.Panel damage	Check or changeover
		4.Safety belt fail, not working	Check or changeover

5	Safety belt fails to protruding or retrieving	1.Ratcher structure of the device retrieving fail	Check or changeover
		2.Wrest spring inner device damage	Check or changeover
6	Cell charged, platform climbing slowly or can not climbing up	1.Insufficient charging	Re-charge
		2.Cell damage	Change new cell
		3.Charger fail	Check or changeover the charger
7	Obvious low voltage but buzzer not to beep	1.Wire off or buzzer fail	Check or changeover
		2.Buzzer circuit damage	Check or changeover
8	Abnormal sound from platform up/down transmission	1.Chain elongated	Adjust to proper
		2.Sprocket loosening or shift	Check, adjust or fix
		3.Sprocket wheel damage	Check or changeover
		4.Other commissioning part worn out, deformation	Check or changeover

8. Diagram

(1) Diagram of Electric Control

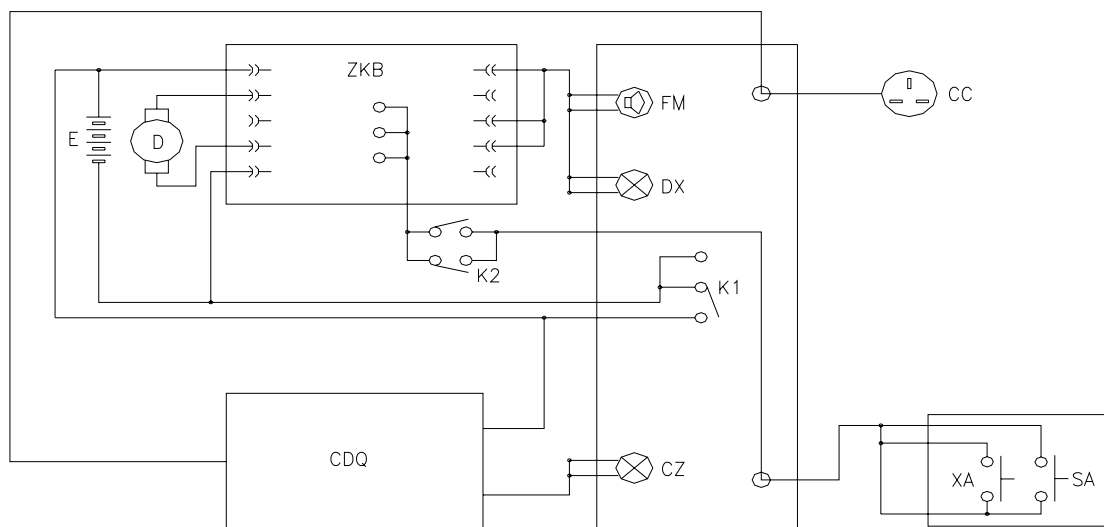

E	24VDC Supply	D	DC Motor
CC	Socket of Charger	FM	Buzzer
DX	Power Indication	CDQ	Charger
CZ	Charging Status	SA	UP Button
XA	DOWN Button	K1	Power Supply Switch
K2	Up/Down Limit Switch	AKB	Main Control Circuit Board

(2) Sketch Map of Electric Panel

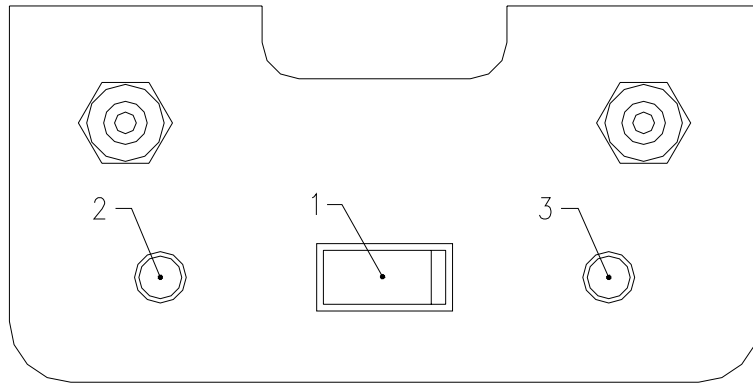

1	Power Supply Switch
2	Power Indication
3	Charging Status

9. Exploded View

(1)

Single Pole Electric Elevator

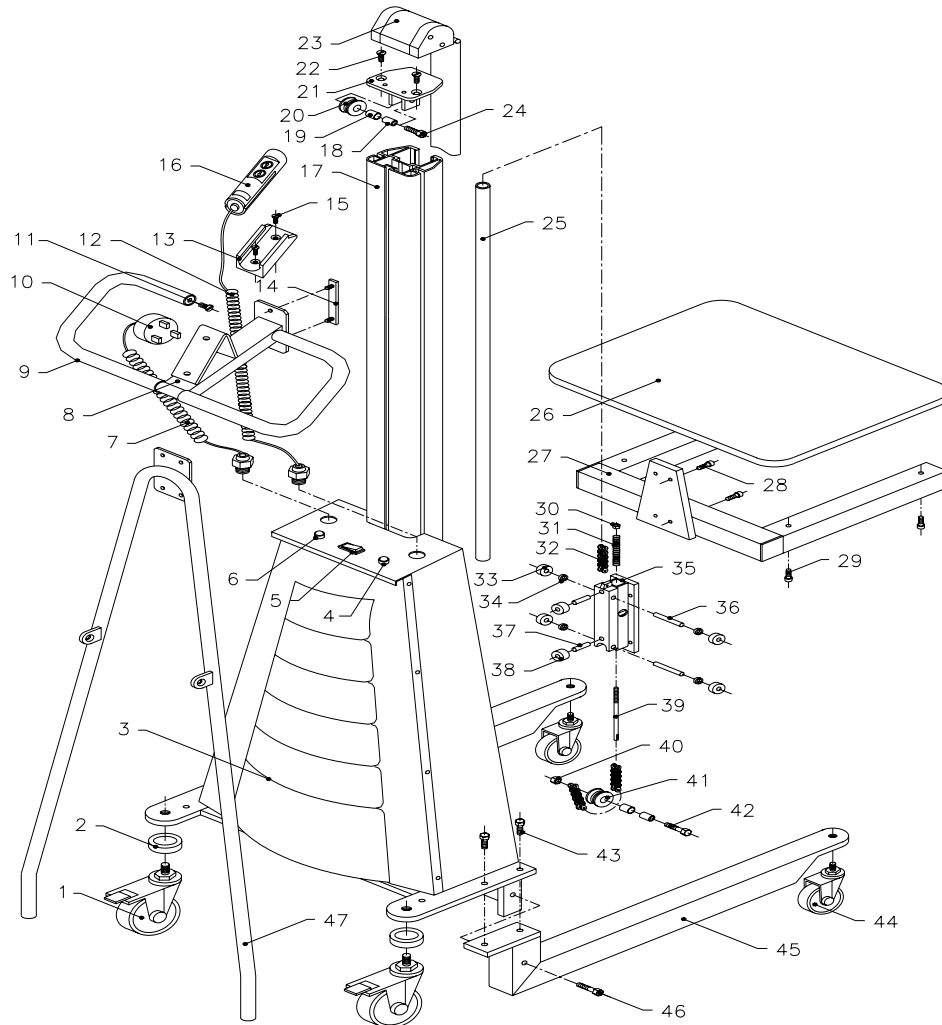

(2) Electric Box

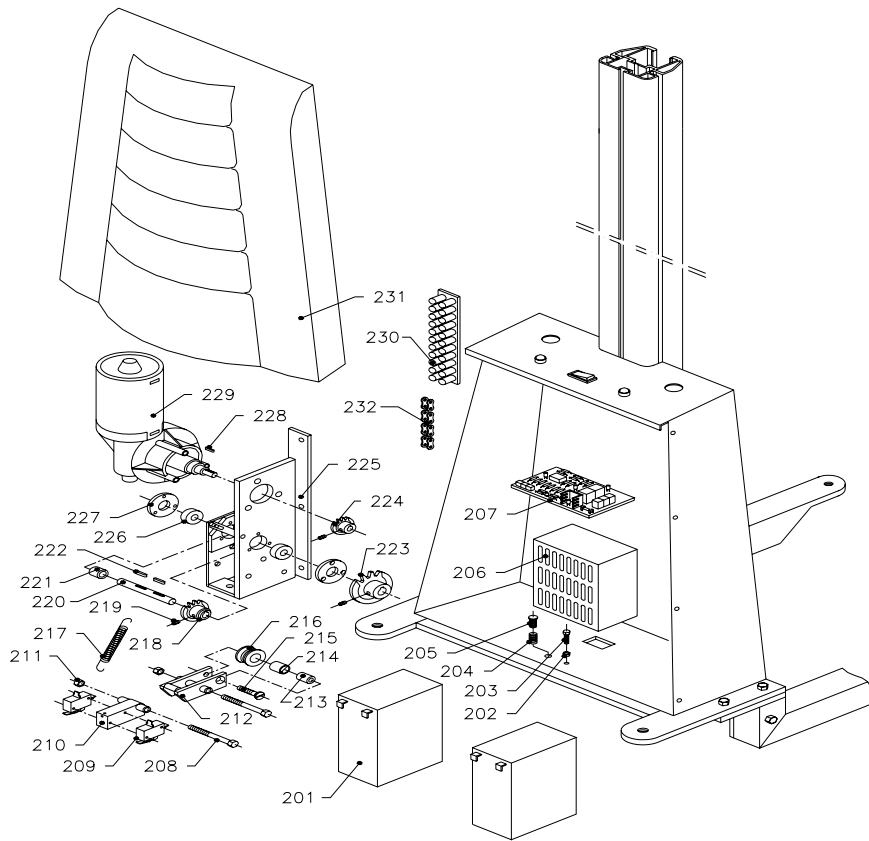

10. Part List

(1) Single Pole Electric Elevator

No.	Description	Qty	No.	Description	Qty
1	Rear Wheel	2	25	Chain Bush	1
2	Washer	2	26	Platform	1
3	Electric Box	1	27	Fixed Racket	1
4	Charging Status	3	28	Inner Hex Bolt	4
5	Power Supply Switch	1	29	Inner Hex Bolt	4
6	Power Indication	1	30	Nut	1
7	Spring Wire	1	31	Spring	1
8	Handrails	1	32	Precision Roller Chain	1
9	Protective Cover	2	33	Bearing	4
10	Charger Pin	1	34	Interval Ring	4
11	Sunk Bolt	2	35	Up/Down Bearing Seat	1
12	Spring Wire	1	36	Pin Shaft	2
13	Electric Control Seat	1	37	Small Trolley Shaft	2
14	Connecting Bolt	4	38	Small Trolley	2
15	Sunk Bolt	4	39	Chain Bolt	1

16	Hand Electric Panel	1	40	Nut	1
17	Ai-Alloy Pole	1	41	Lower Trolley	1
18	Bush	2	42	Hex Bolt	1
19	Oil-free Bearing	2	43	Hex Bolt	4
20	Upper Trolley	1	44	Front Wheel	2
21	Upper Trolley Seat	1	45	Front Wheel Fork	2
22	Sunk Bolt	2	46	Hex Bolt	2
23	Safety Belt	1	47	Pole Pulling Pipe	1
24	Hex Bolt	1			

(2) Electric Box

No.	Description	Qty	No.	Description	Qty
201	(Storage) Cell	2	217	Pull Spring	1
202	Nut	1	218	Transmission Chain Wheel	1
203	Hex Bolt	1	219	Top Prick Fixing Bolt	3
204	Spring	1	220	Transmission Shaft	1
205	Adjustable Bolt	1	221	Interval Ring	1
206	Charger	1	222	Plain Pin	2
207	Circuit Board	1	223	Big Chain Wheel	1
208	Hex Bolt	2	224	Motor Chain Wheel	1
209	Traveling Switch	2	225	Motor Seat	1
210	Traveling Switch Seat	1	226	Bearing	2
211	Nut	2	227	Bearing Lid	2
212	Flexible Racket	1	228	Plain Pin	1
213	Bush	1	229	Motor	1
214	Oil-free Bearing	1	230	Wiring Bar	1
215	Sunk Bolt	1	231	Electric Box Lid	1
216	Flexible Trolley	1	232	Chain of Electric Machinery	1