

A	B <sup>+0.000</sup> <sub>-0.015</sub>	C <sup>+0.002</sup> <sub>-0.000</sub>	D
NOMINAL SHAFT DIAMETER	BOTTOM OF SHAFT TO BOTTOM OF KEYWAY	WIDTH	REFERENCE DEPTH
0.3750	0.322	0.094	0.053
0.4375	0.386	0.094	0.052
0.5000	0.430	0.125	0.070
0.5625	0.493	0.125	0.070
0.6250	0.517	0.188	0.108
0.6875	0.581	0.188	0.107
0.7500	0.644	0.188	0.106
0.8125	0.708	0.188	0.105
0.8750	0.771	0.188	0.104
0.9375	0.796	0.250	0.142
1.0000	0.859	0.250	0.141
1.0625	0.923	0.250	0.140
1.1250	0.986	0.250	0.139
1.1875	1.049	0.250	0.138
1.2500	1.112	0.250	0.138
1.3125	1.136	0.313	0.176
1.3750	1.201	0.313	0.175
1.4375	1.224	0.375	0.214
1.5000	1.289	0.375	0.211
1.5625	1.351	0.375	0.211
1.6250	1.416	0.375	0.209
1.6875	1.478	0.375	0.209
1.7500	1.542	0.375	0.208
1.8125	1.526	0.500	0.287
1.8750	1.591	0.500	0.284
1.9375	1.654	0.500	0.284
2.0000	1.718	0.500	0.282
2.0625	1.781	0.500	0.282
2.1250	1.845	0.500	0.280
2.1875	1.908	0.500	0.280
2.2500	1.972	0.500	0.278
2.3125	1.956	0.625	0.357
2.3750	2.021	0.625	0.354
2.4375	2.083	0.625	0.354
2.5000	2.148	0.625	0.352

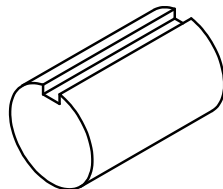
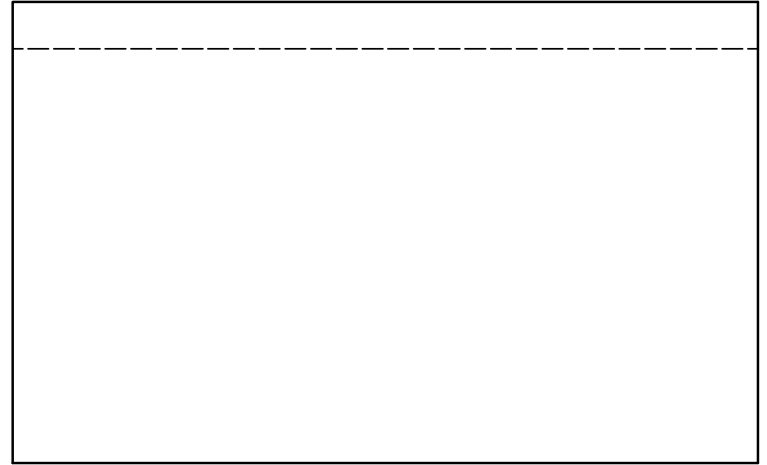
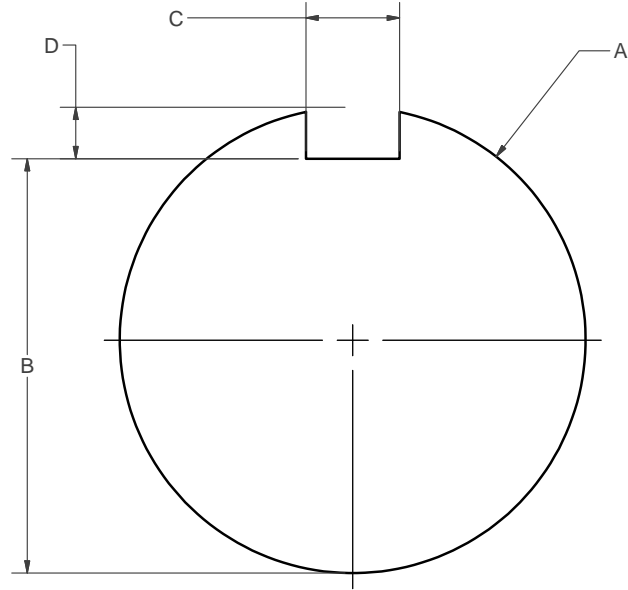

**UNLESS OTHERWISE SPECIFIED**  
 ALL DIAMETERS TO BE  
 CONCENTRIC WITHIN 0.003  
 REMOVE ALL BURRS  
 & SHARP EDGES

**JRC WEB ACCESSORIES**  
 46 PASSAIC AVENUE FAIRFIELD, NJ 07004

CUSTOMER	DIMENSION	TOLERANCE ±
FINISH	FRACTIONAL	1/64
MATERIAL	ANGULAR	0.5°
REFERENCE DRAWING	X.XX	0.010
	X.XXX	0.005
	X.XXXX	0.0005

TITLE			
<b>KEYWAY AND SHAFT DIMENSIONS</b>			
SIZE	DATE	DWG NO	REV
B		<b>B-7249</b>	
SCALE	DRAWN	SHEET 1	OF 1